

<b>1</b>	<b>Function</b>	AEA-12
	1.1 Input voltage range .....	AEA-12
	1.2 Inrush Current Limiting .....	AEA-12
	1.3 Overcurrent protection .....	AEA-12
	1.4 Peakcurrent protection .....	AEA-12
	1.5 Overvoltage protection .....	AEA-12
	1.6 Output voltage adjustment range .....	AEA-12
	1.7 Thermal protection .....	AEA-12
	1.8 Output ripple and ripple noise .....	AEA-12
	1.9 Isolation .....	AEA-13
<b>2</b>	<b>Series Operation and Parallel Operation</b>	AEA-13
	2.1 Series Operation .....	AEA-13
	2.2 Parallel operation/master-slave operation .....	AEA-13
	2.3 N+1 Parallel Redundancy Operation .....	AEA-13
<b>3</b>	<b>Life expectancy and Warranty</b>	AEA-14
<b>4</b>	<b>Peak current</b>	AEA-14
<b>5</b>	<b>Ground</b>	AEA-15
<b>6</b>	<b>Options</b>	AEA-15
	6.1 Outline of Options .....	AEA-15
	6.2 Medical Isolation Grade .....	AEA-18

# 1 Function

## 1.1 Input voltage range

- The range is from 85VAC to 264VAC.

In cases that conform with safety standard, input voltage range is 100VAC to 240VAC (50/60Hz).

- If input value doesn't fall within above range, a unit may not operate in accordance with specifications and/or start hunting or fail.

If you need to apply a square waveform input voltage, which is commonly used in UPS and inverters, please contact us.

- When the input voltage changes suddenly, the output voltage accuracy might exceed the specification. Please contact us.

If the restart time of the short interruption power failure is less than 3 seconds, perform a thorough evaluation.

- A unit can operate under the input voltage dip with derating.

Table 1.1 and 1.2 shows the load factors that can be output.

Table 1.1 IEC60601-1-2 Maximum output load factor

Voltage dip	Duration [ms]	Load factor
100VAC → 0VAC	20	100%
100VAC → 40VAC	100	100%
100VAC → 70VAC	500	100%
240VAC → 0VAC	20	100%
240VAC → 96VAC	100	100%
240VAC → 168VAC	500	100%

Table 1.2 SEMI F47-0706 Maximum output load factor

Voltage dip	Duration [ms]	Load factor
100VAC → 50VAC	200	100%
100VAC → 70VAC	500	100%
100VAC → 80VAC	1000	100%
200VAC → 100VAC	200	100%
200VAC → 140VAC	500	100%
200VAC → 160VAC	1000	100%

\* 100% Load factor in table 1.1 and 1.2 means the rated current (forced air cooling) in Specifications.

## 1.2 Inrush Current Limiting

- An inrush current limiting circuit is built-in.
- If you need to use a switch on the input side, please select one that can withstand an input inrush current.
- Relay technique is used in the inrush current limiting circuit. When you turn the power ON/OFF repeatedly within a short period of time, please have enough intervals so that the inrush current limiting circuit becomes operative.
- When the switch of the input is turned on, the primary inrush current and secondary inrush current will be generated because the relay technique is used for the inrush current limiting circuit.

## 1.3 Overcurrent protection

- Overcurrent protection is built-in and comes into effect over 101% of the peak current in. Overcurrent protection prevents the unit from short circuit and overcurrent condition.

The unit automatically recovers when the fault condition is cleared.

## ■ Intermittent Operation Mode

Intermittent operation for overcurrent protection is included in a part of series. When the overcurrent protection circuit is activated and the output voltage drops to a certain extent, the output becomes intermittent so that the average current will also decrease.

- When the overcurrent protection continues, the output will be shut down.
- Output voltage recovers from overcurrent protection by shutting down the input voltage and waiting more than 3 minutes then turning on AC input again.

## 1.4 Peakcurrent protection

- Peakcurrent protection is built-in (The protection circuit operates when load current exceeds the rating current and the use deviates from the condition in Instruction Manual 4).

The output will be recovered automatically after removing causes of the fault.

## 1.5 Overvoltage protection

- An overvoltage protection circuit is built-in. If the overvoltage protection circuit is activated, shut down the input voltage, wait more than 3 minutes and turn on the AC input again to recover the output voltage. Recovery time varies depending on such factors as input voltage value at the time of the operation.

### Remarks :

Please avoid applying a voltage exceeding the rated voltage to an output terminal. Doing so may cause a power supply to malfunction or fail. If you cannot avoid doing so, for example, if you need to operate a motor, etc., please install an external diode on the output terminal to protect the unit.

## 1.6 Output voltage adjustment range

- To increase an output voltage, turn a built-in potentiometer clockwise. To decrease the output voltage, turn it counterclockwise.

## 1.7 Thermal protection

- Thermal protection circuit is built-in and shut down under following condition.

- ① When the current and the temperature which exceed from the derating curve.
- ② The case FAN stops or air flow is interrupted and the amount of the wind decreases.

If the thermal protection activates, shut off input voltage, remove the cause of the overheating, wait for the unit to cool down, and recycle to recover output voltage.

## 1.8 Output ripple and ripple noise

- Output ripple noise may be influenced by measurement environment, measuring method Fig.1.1 is recommended.

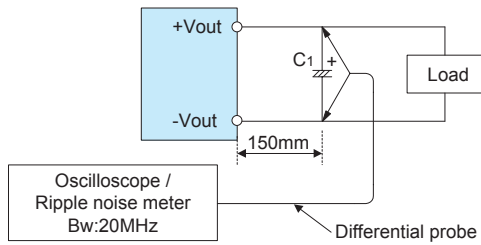

C1 : Aluminum electrolytic capacitor 22μF

Fig.1.1 Measuring method of Ripple and Ripple Noise

**Remarks :**

When GND cable of probe with flux of magnetic force from power supply are crossing, ripple and ripple noise might not measure correctly.

Please note the measuring environment.

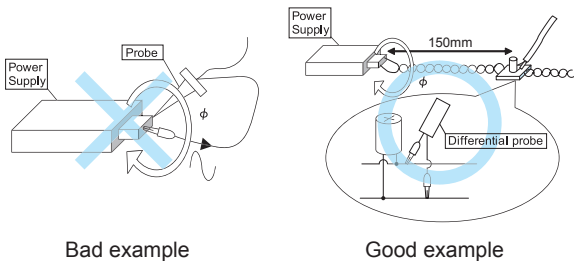

Fig.1.2. Example of measuring output ripple and ripple noise

**1.9 Isolation**

For a receiving inspection, such as Hi-Pot test, gradually increase (decrease) the voltage for the start (shut down). Avoid using Hi-Pot tester with the timer because it may generate voltage a few times higher than the applied voltage, at ON/OFF of a timer.

**2 Series Operation and Parallel Operation**

**2.1 Series Operation**

You can use a power supply in series operation. The output current in series operation should be lower than the rated current of a power supply with the lowest rated current among power supplies that are serially connected. Please make sure that no current exceeding the rated current flows into a power supply.

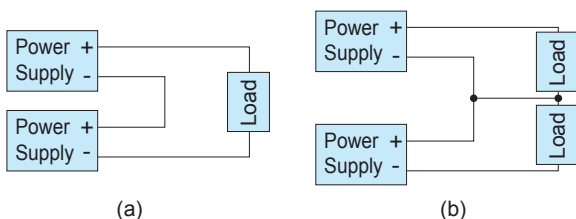

Fig.2.1 Examples of connecting in series operation

In series operation, the maximum operative number of units is 9. The combined output voltage of series operation is 200V.

**2.2 Parallel operation/master-slave operation**

As variance of output current drawn from each power supply is maximum 10%, the total output current must not exceed the value determined by the following equation.

$$\left[ \text{Output current in parallel operation} \right] = \left[ \frac{\text{The rated current per unit}}{\text{}} \right] \times (\text{Number of unit}) \times 0.9$$

When the number of units in parallel operation increases, input current increases at the same time. Adequate wiring design for input circuitry is required, such as circuit pattern, wiring and current capacity for equipment.

In parallel operation, the maximum operative number of units is 6.

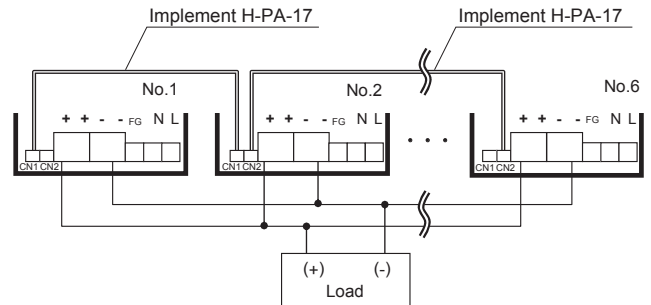

Fig.2.2 Connection method in parallel

Output voltage in parallel operation is adjustable by using the potentiometer of the "master" unit. Select one power supply to be the master, and turn the potentiometer of the other, "slave" power supplies, clockwise to the end. Then use the potentiometer of the master to adjust output voltage.

In series operation or parallel operation, output voltage increases like stairs due to a delay of the rise time of output voltage at turn on.

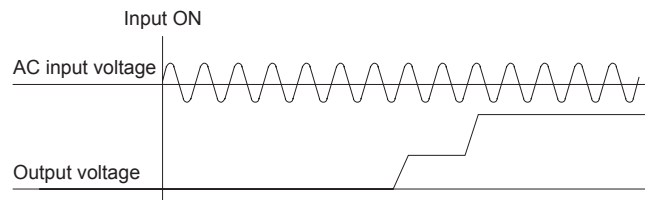

Fig.2.3 Start-up wave form in series and/or parallel operation

**2.3 N+1 Parallel Redundancy Operation**

You can have N+1 redundancy operation for improving system reliability.

If you add one extra power supply in parallel operation, even if one of the power supplies in your system fails, the remaining non-failed power supplies continue to sustain the system. If one of the power supplies stops operating, the output voltage may change about 5%.

When unit replacement is required due to unit failure, input voltage for all units must be cut off.

- After replacement, please make sure that all wirings are completed correctly, before re-applying input voltage.
- Hot-swap or Hot-plug is not available.
- If 2 or more units failed, sufficient power could not be provided to the system. Therefore, please replace the failed unit immediately in case where unit failure is found.
- If you have any questions about series, parallel and N+1 redundancy operations, please contact us.

### 3 Life expectancy and Warranty

■ Life expectancy  
Life expectancy is as follows.

Table3.1 Life expectancy

Mount	Average ambient temperature (yearly)	Life expectancy	
		$Io \leq 50\%$	$50 < Io \leq 100\%$
All mounting direction	$Ta \leq 30^\circ C$	10 years or more	10 years or more
	$Ta = 40^\circ C$	10 years or more	6 years
	$Ta = 50^\circ C$	5 years	3 years
Forced air	$Ta \leq 30^\circ C$	10 years or more	10 years or more
	$Ta = 40^\circ C$	10 years or more	6 years
	$Ta = 50^\circ C$	5 years	3 years

■ Warranty  
The warranty is 5 years when average ambient temperature of year is  $Ta = 50^\circ C$  or less and load factor is average 50% or less. However, the warranty is 3 years when average ambient temperature of year is  $Ta = 50^\circ C$  or less and load factor is series 100%.

### 4 Peak current

■ Peak current can be used at the below condition.

- $t_1 \leq 5\text{sec}$
- $I_p \leq \text{Rated peak current}$
- $I_{rms} \leq \text{Rated current}$
- $I_{rms}^2 = \frac{I_p^2 \times t_1 + I_L^2 \times t_2}{t_1 + t_2}$

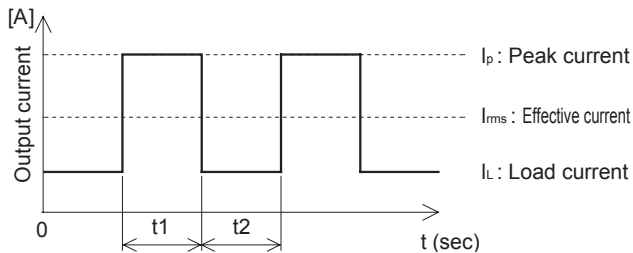

Fig.4.1 Peak current

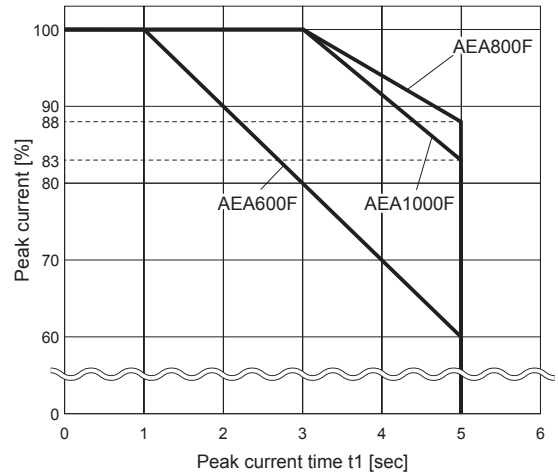

Fig.4.2 Relation between Peak current time and Peak current

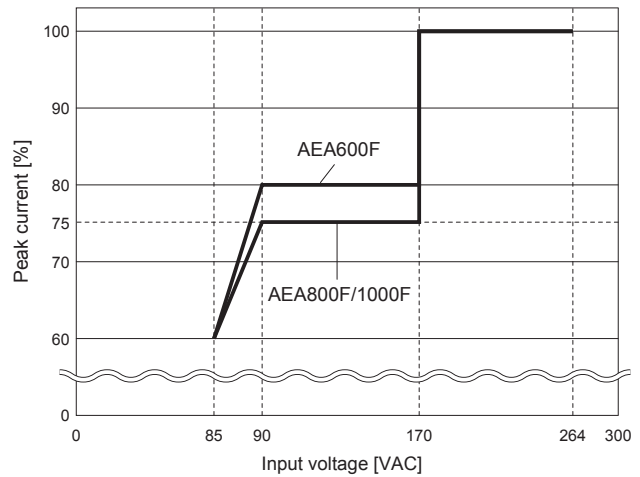

Fig.4.3 Derating curve depends on input voltage

■ Ex. Peak current calculation

Model : AEA600F-24

Conditions :

$V_{in} : 100\text{VAC}$  Cooling method : convection cooling  $Ta : 40^\circ C$

$I_p = 30\text{A}$ ,  $t_1 = 3\text{sec}$

$I_L = 10\text{A}$ ,  $t_2 = 40\text{sec}$

① Calculate  $I_{rms}$

$$I_{rms}^2 = \frac{I_p^2 \times t_1 + I_L^2 \times t_2}{t_1 + t_2} = \frac{30^2 \times 3 + 10^2 \times 40}{3 + 40} = 155.81$$

$$I_{rms} = \sqrt{155.81} = 12.48$$

② Allowed  $I_p$  max

Input voltage derating @100VAC = 80%

Peak current time derating @  $t_1 : 3\text{sec}$  = 80%

$$I_p \text{ max} = 52.5 (\text{Rated peak current}) \times 80\% \times 80\% = 33.6\text{A}$$

### ③ Allowed $I_{rms}$ max

Input voltage derating @100VAC = 80%

Ambient temperature derating  $T_a:40^{\circ}C = 100\%$

$$I_{rms} \text{ max} = 17.5 \text{ (Rated current convection cooling)} \times 80\% \times 100\% = 14A$$

### ④ Judgment

$I_p$  and  $I_{rms}$  do not exceed the maximum condition. Pass

## 5 Ground

■ When installing the power supply with your unit, ensure that the mounting hole FG is connected to safety ground of the unit.

\* It is recommended to electrically connect terminal FG and mounting hole FG to metal chassis for reducing noise.

## 6 Options

### 6.1 Outline of Options

#### ● -C

- Except a certain (e.g.terminal, potentiometer), PCB is coated.

#### ● -N

- Option -N models come with a cover.
- Appearance of Option -N models are different from that of standard models. Please see External View for details.
- Derating curve for Option -N models is different from that for standard models. Please see "Derating" for details.

#### ● -T

- Option -T models have vertically positioned screws on a terminal block.
- Please contact us for details about appearance.

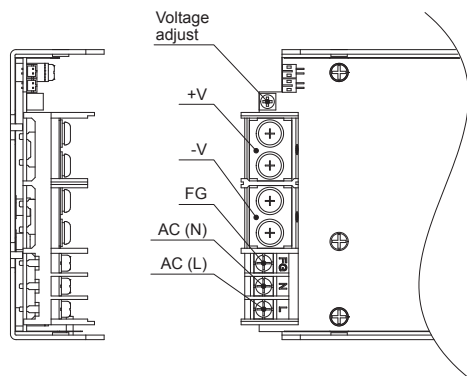

Fig.6.1 Example of option -T

#### ● -J

- J means terminal block is changed to connector. (Mfr : TE Connectivity).
- Please contact us for details about appearance.

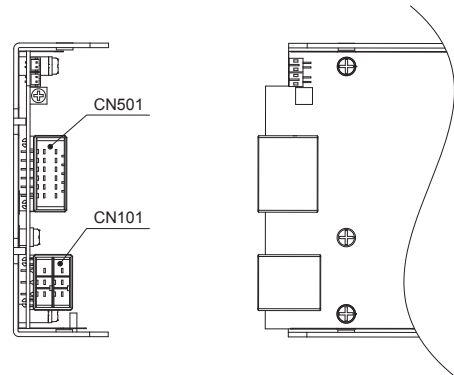

Fig.6.2 Example of option -J

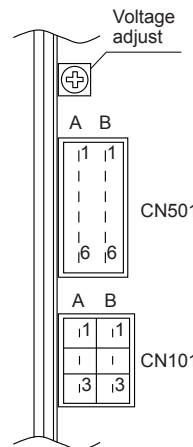

Table 6.1 Pin assignments of CN101

	Pin no.	Input
A	1	N
	2	NC
	3	L
B	1	N
	2	NC
	3	L

Table 6.2 Pin assignments of CN501

	Pin no.	Output
A	1	+V
	2	+V
	3	+V
	4	-V
	5	-V
	6	-V
B	1	+V
	2	+V
	3	+V
	4	-V
	5	-V
	6	-V

Table 6.3 Mating connectors and terminals on CN101 and CN501

Connector	Housing	Terminal	Mfr	
CN101	1-178139-5	1-178129-6	1-175218-5 equivalent goods	TE Connectivity
CN501	178306-5	178289-6	1-353717-5 equivalent goods	

\*Keep drawing current per pin below 8.5A

#### ● -R3

- Option -R3 models provide AUX1 (12V), AUX2 (5V), remote ON/OFF control and alarms (PR,PG alarm).
- Please refer to the optional parts for the dedicated harness.
- Please contact us for details about appearance.

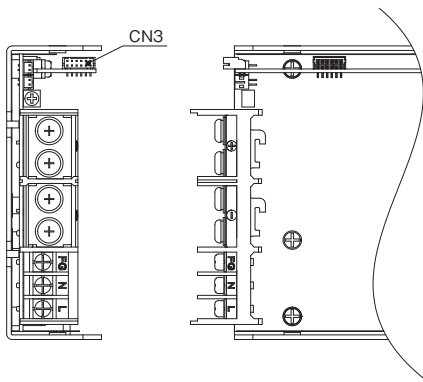

Fig.6.3 Example of option -R3

Table 6.4 Pin assignments of CN3

Pin no.	Function
1	AUX1 : AUX1 (12V1A)
2	AUX1G : AUX1 (GND)
3	AUX2 : AUX2 (5V1A)
4	AUX2G : AUX2 (GND)
5	AUX2 : AUX2 (5V1A)
6	AUX2G : AUX2 (GND)
7	RC : Remote ON/OFF
8	RCG : Remote ON/OFF (GND)
9	PG : PG Alarm
10	PGG : PG Alarm (GND)
11	PR : PR Alarm
12	PRG : PR Alarm (GND)

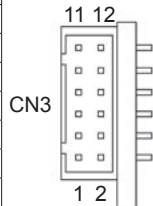

Table 6.5 Mating connectors and terminals on CN3

Connector	Housing	Terminal	Mfr
CN3	S12B-PHDSS PHDR-12VS	Reel : SPHD-002T-P0.5 Loose : BPHD-001T-P0.5 *1 BPHD-002T-P0.5 *1	J.S.T.

\*1 The manufacturer can offer only ratchet hand tool

- AUX1 12V0.3A (convection cooling), 12V1A (forced air)
  - This power supply is equipped with an auxiliary 12V output AUX1 (12V±5%) for forced air cooling which is available from CN3.
  - AUX1 is not isolated from the main output circuit.
  - Do not connect AUX1G- to -Vout as current may flow through AUX1 (fig 6.4).
  - Do not exceed the current rating, it may causes malfunction or failure of the internal circuitry.

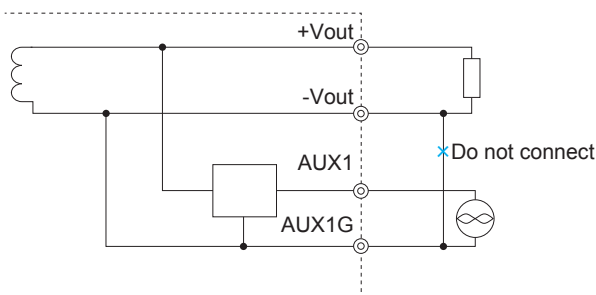

Fig.6.4 When using AUX1

- AUX2 5V0.5A (convection cooling), 5V1A (forced air)
  - Output AUX2 is provided from CN3. AUX2 (5V±5%) can be used to power up remote control or other circuits.
  - AUX2 has been isolated from other circuit (input, output, FG, RC).
  - Do not exceed the current rating, it may causes malfunction or failure of the internal circuitry.

■Remote ON/OFF

- You can operate the remote ON/OFF function by sending signals to CN3. Please see Table 6.6 for specifications and Fig.6.5 for connecting examples.
- Remote ON/OFF circuits (RC and RCG) are isolated from input, output FG and AUX.
- Please note the following when using the remote ON/OFF function.
  - ①Turns on by drawing current to RC.
  - ②The current flown to RC is a 5mA typ (maximum 25mA).
  - ③If the output voltage is turned off through the remote ON/OFF circuit, AUX1 stops.
  - ④If current of a value not listed in Table 6.6 is applied between RC and RCG, the output voltage may not be generated normally.
  - ⑤Please wire carefully. If you wire wrongly, the internal components of a unit may be damaged.

\* If the output of an external power supply is within the range of 4.5 - 12.5V, you do not need a current limiting resistor R1. If the output exceeds 12.5V, however, please connect the current limiting resistor R1.

R1 Recommended resistor [ $\Omega$ ]	$R_i : 780[\Omega]$
$R1 = \frac{V1 - (1.1 + R_i \times 0.005)}{0.005}$	

Table 6.6 Specifications of remote ON/OFF

Fig.6.5 RC circuit example	-R3	
SW Logic	Output on	SW short (3mA min)
	Output off	SW open (0.1mA max)

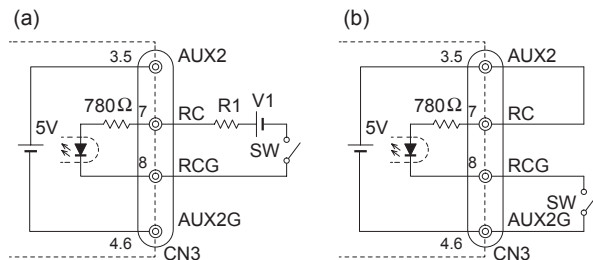

Fig.6.5 RC circuit example

## Alarm

- ① PR: abnormal input voltage
- ② PG: drop and shut-off of output voltage

Table 6.7 Explanation of alarms

Alarm		Output of alarm
PR	When the input voltage is abnormal (low input voltage), the alarm signal is output from CN3.	Open collector method Good : Low (0-0.8V, 1mA max) Bad : High or open (50V max)
PG	When the rated output voltage decreases or stops, the alarm signal is output from CN3. Note : When the overcurrent protection activated, the PG alarm will be unstable.	Open collector method Good : Low (0-0.8V, 1mA max) Bad : High or open (50V max)

The alarm circuits (PR and PG) are isolated from others (the input, outputs, FG, AUX and other function terminals).

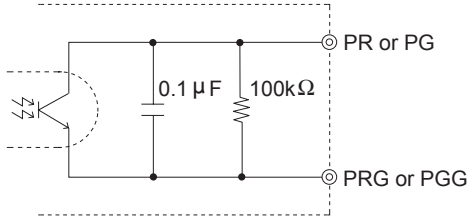

Fig 6.6 internal circuit of PR or PG

## -T5

- Acquired UL508.
  - UL 62368-1 and EN62368-1 are compliant. (Only AEA600F)
  - Safety approvals will be invalid with forced air.
  - CN1 and CN2 will be changed to push-in type terminal blocks.
  - AEA600F-32 does not support this option.
- Please contact us for any other conditions.

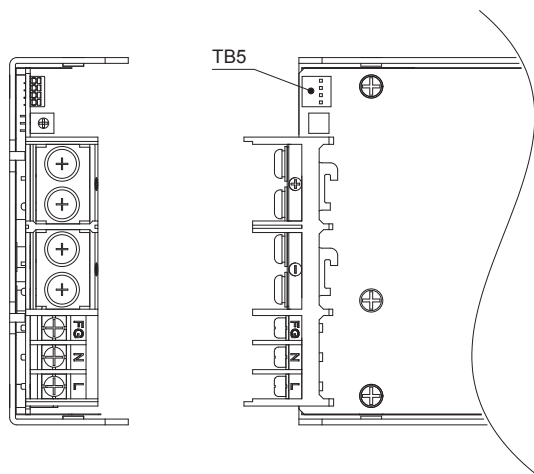

Fig 6.7 Example of option T5

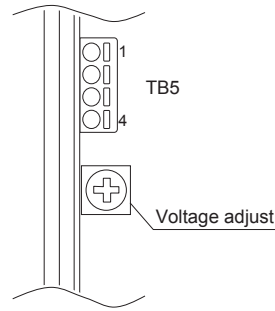

Table 6.8 Pin assignments of TB5

Pin no.	Input
1	VB
2	CB
3	VB
4	CB

Table 6.9 Recommended Ferrule terminals

Type	Manufacturer	Wire size	Model	Crimp tool
Square type	Phoenix Contact	AWG 20	AI0.5-6WH	CRIMPFOX
		AWG 22	AI0.34-6TQ	CENTRUS
		AWG 24 - 26	AI0.25-6BU	6S

Table 6.10 Applicable wire size (Solid wire, Stranded wire)

Wire size	AWG 20 - 26
Wire insulation strip length	6mm

Fig.6.8, Fig.6.9 and Fig.6.10 is the how to connect/release the wire.

- How to connect the Ferrule terminals and the solid wire
- Step1: Insert the wire until the electrode is not visible. (Refer to the fig.6.8(a).)
- Inserting a flat-blade screwdriver into the release hole makes it easier to insert. (Refer to the fig.6.8(b).)
- Step2: Pull the wire lightly in order to make sure it is fixed.

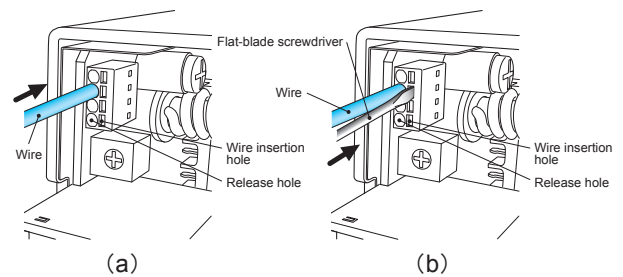

Fig.6.8 Connecting method of Ferrule terminal and Solid wire

- How to connect the stranded wire
- Step1: Insert a flat-blade screwdriver into the release hole. (Refer to the fig.6.9(a).)
- Step2: Insert the wire until the electrode is not visible with the flat-blade screwdriver inserted in the release hole. (Refer to the fig.6.9(b).)
- Step3: Remove the flat-blade screwdriver from the release hole. (Refer to the fig.6.9(c).)
- Step4: Pull the wire lightly in order to make sure it is fixed.



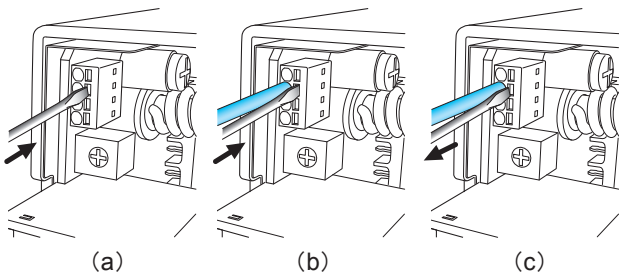

Fig.6.9 Connecting method of Stranded wire

· How to release the Ferrule terminal, Solid wire and Stranded wire

Step1: Insert a flat-blade screwdriver into the release hole. (Refer to the fig.6.10(a).)

Step2: Remove the wire with the flat-blade screwdriver inserted in the release hole. (Refer to the fig.6.10(b).)

Step3: Remove the flat-blade screwdriver from the release hole. (Refer to the fig.6.10(c).)

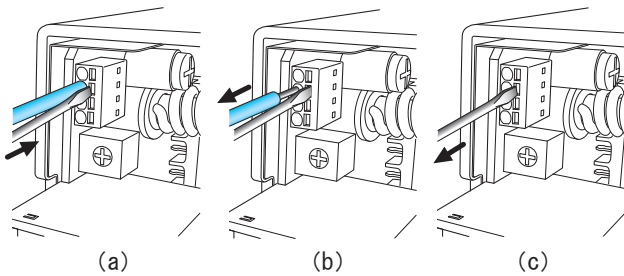

Fig.6.10 Releasing method of Ferrule terminal, Solid wire and Stranded wire

● -P5

- Overcurrent protection will be changed to shut down mode from hic-cup mode.
- Please contact us for any other conditions.

## 6.2 Medical Isolation Grade

■ AEA series fit 2MOPP

■ Type BF

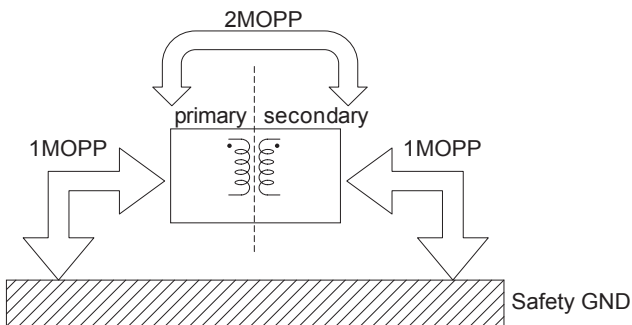

Fig.6.11 Medical Isolation Grade